

Sound Acoustics

Premium Residential & Commercial Audio/Video Products



CT-10 **Commercial Tuner / Amplifier**

Owner's Manual

IMPORTANT NOTE: THIS OWNER'S MANUAL IS PROVIDED AS AN INSTALLATION AND OPERATING AID. SOUND ACOUSTICS DOES NOT ASSUME ANY RESPONSIBILITY AS TO ITS ACCURACY AND SHALL NOT BE LIABLE IN TORT OR CONTRACT FOR ANY DIRECT, CONSEQUENTIAL OR INCIDENTAL LOSS OR DAMAGE ARISING FROM THE INSTALLATION, USE OR INABILITY TO USE THIS PRODUCT.

WARNING: TO REDUCE THE RISK OF FIRE OR ELECTRIC SHOCK DO NOT EXPOSE THIS APPLIANCE TO WATER, RAIN OR MOISTURE.

CAUTION: TO PREVENT ELECTRIC SHOCK, DO NOT OPEN.

Immediately upon receipt, inspect the unit and shipping container for indications of improper handling or in-transit damage. This equipment was carefully inspected and tested before leaving the factory. Notify the Transportation Company, Wholesaler or Retailer immediately if any damage is found. Be sure to save the carton and packing material as evidence of damage for later inspection. DO NOT SHIP the unit back to the factory unless authorized to do so by the factory. IN TRANSIT DAMAGES ARE NOT COVERED BY THE WARRANTY. **DO NOT INSTALL OR ATTEMPT TO OPERATE THIS UNIT IF IT HAS BEEN DAMAGED.**

IMPORTANT SAFETY INSTRUCTIONS

- Read and keep these instructions.
- Heed all warnings and follow all instructions contained within this manual.
- Do not use this unit near water.
- Clean only with dry cloth.
- Do not block any ventilation openings. Install in accordance with the manufacturer's instructions.
- Do not install near any heat sources such as radiators, heat registers, stoves, or other apparatus (including amplifiers) that produce heat.
- Do not defeat the safety purpose of the polarized or grounding-type plug. A polarized plug has two blades with one wider than the other. A grounding type plug has two blades and a third grounding prong. The wide blade or the third prong are provided for your safety. If the provided plug does not fit into your outlet, consult an electrician for replacement of the obsolete outlet.
- Protect the power cord from being walked on or pinched particularly at plugs, convenience receptacles, and the point where they exit from the apparatus.
- Only use attachments/accessories specified by the manufacturer.
- Unplug this apparatus during lightning storms or when unused for long periods of time.
- Refer all servicing to qualified service personnel. Servicing is required when the apparatus has been damaged in any way, such as when the power-supply cord or plug is damaged, liquid has been spilled or objects have fallen into the apparatus, the apparatus has been exposed to rain or moisture, does not operate normally, or has been dropped.
- Operate the product only with the voltage specified on the unit. Fire and/or electric shock may result if a higher voltage is used.
- Do not modify, kink, or cut the power cord. Do not place the power cord in close proximity to heaters and do not place heavy objects on the power cord and/or the product itself, doing so may result in fire or electrical shock.
- Replace the protective cover over the speaker terminals after installation. Do not touch the 70V speaker terminals as electric shock may result.
- Ensure that the safety ground terminal is connected to a proper ground. Never connect the ground to a gas pipe, as a severe explosion and/or fire may result.
- Be sure the installation of this product is stable, avoid slanted surfaces as the product may fall and cause injury, property damage, electrocution and/or fire.

Introduction

Congratulations and thank you for purchasing a Sound Acoustics product. The Sound Acoustics "C" series amplifiers are designed and built to provide ultra reliable performance for professional background music and paging applications. All Sound Acoustics amplifiers feature color coded inputs and outputs, ultra low noise components, front panel auxiliary inputs and PRO-RVC remote control inputs. Sound Acoustics inputs are very flexible and will accept practically any source and source level. This frees the installer to design the system to suit the customers needs exactly. The CT-10 is a unique Tuner Amplifier that offers dual output zones, comprehensive PC control of the tuner section and the ability to add remote microphones and line level sources practically anywhere. Please read this entire manual to get the most from your Sound Acoustics C-540T.

Quick Start: To get up a running quickly connect your 8 ohm or 25V or 70V speakers to the speaker outputs. Connect the negative - speaker wire to the common C terminal and the positive + speaker wire to the appropriate speaker terminal 25,70,100V or 4 ohm. Connect the included AM antenna to the back panel AM terminals and the back panel FM input to your cable vision outlet or the FM antenna included with your CT-10. Plug in the AC power cord to an AC120V 60 Hz power outlet.

1. Press Auto Scan on the front panel. The CT-10 will automatically scan all AM then FM stations and load them into the preset memory in ascending order.
2. To hear the presets push the front panel pre-set buttons 1-6. The stations will be displayed on the front panel display.
3. The CT-10 can store up to 48 pre-set stations. Press the AM/FM buttons repeatedly to cycle through AM1, AM2, AM3, AM4, FM1, FM2, FM3, FM4. Each AM/FM memory level holds 6 presets.
4. Another quick start method. Push then turn the Tune knob and cycle to a station where you know the frequency. Stop on that frequency and the station will be broadcast. To save that station into the memory press the memory button then press memory location button 1-6 then press the memory button again to confirm your selection and the station will be stored in that memory location. This will automatically overwrite the previously stored station in that memory location.
5. One last quick start method. Plug an Mp3 player or iPod player into the front panel Mp3 jack. The device will automatically broadcast on the line outputs and the speaker outputs.

Front Panel Operation and Connections

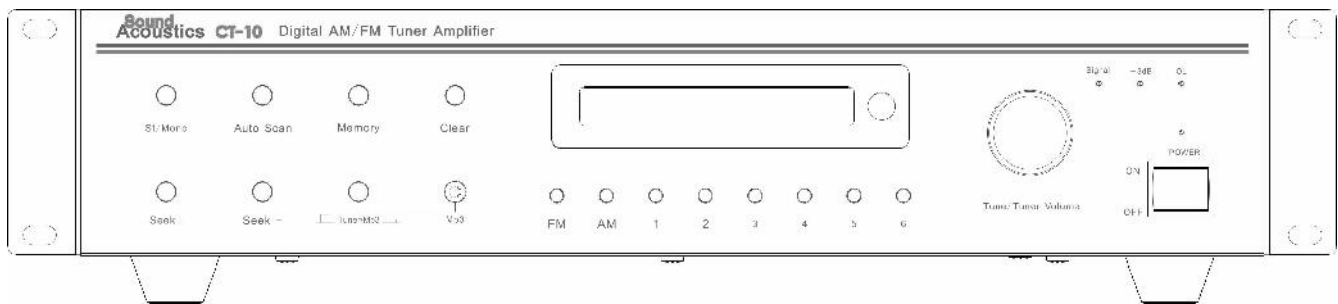

Power On/Off - The Power switch applies power to the amplifier. The Power switch is also part of the protection circuitry of the amplifier. If the amplifier is overloaded it will automatically shut down to protect the circuitry from damage. If this occurs turn the power switch off, turn the master volume down, wait 15 seconds, then turn the Power switch on. The amplifier should return to normal operation.

Signal LED - The Signal LED lights when a signal is present in the master bus output. With a source connected to one of the inputs and the input level turned up to 12:00 turn the Master volume up slowly until the Signal LED lights. With a valid source playing it is normal for the Signal LED to be lit solidly.

-3dB LED - The -3dB LED lights when the signal in the master bus output is 3dB below clipping. This allows the user to adjust levels to prevent clipping and overloading the amplifier.

OL LED - The OL LED is the overload warning light. When the OL LED flashes occasionally it is indicating occasional peaks in the output signal. If the OL LED lights solidly the amplifier is being overdriven. Immediately reduce the input levels and the Master volume control until the OL LED is not illuminated. Occasional flashing is normal.

MP3 Input - The Mp3 input is a stereo 3.5mm 1/8" jack that will accept signals from practically any device with a headphone output jack. Mp3 players, iPod's, portable phones, computers, receivers etc. The Mp3 Input also feeds the music on hold MOH outputs. If a source is connected to the rear panel Input 6 jacks the Mp3 input will automatically override that source when a connector is inserted. It is possible to have two output zones with different sources being broadcast simultaneously by using the Mp3 input or rear panel Input 6 jacks as the source for the MOH output and using any other input as the source for the main outputs. The Mp3 jack is a quick way to connect to the amplifier without needing access to the back panel.

Tuner Operation and Programming

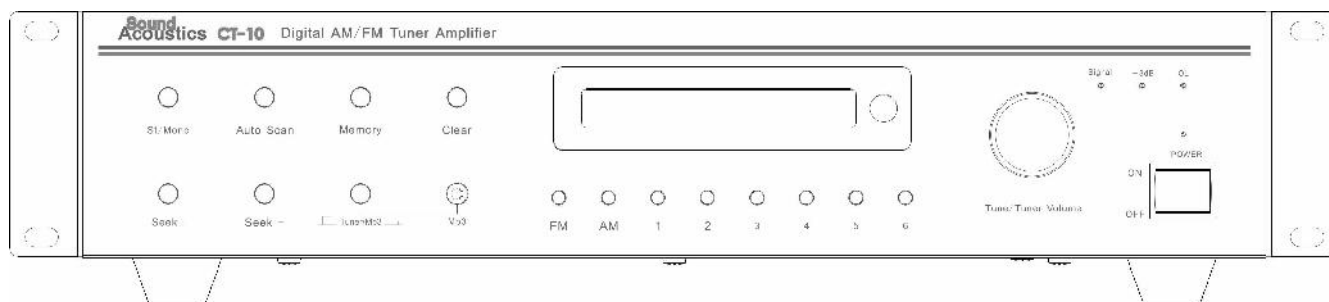

Tune/ Tuner Volume Knob - This push/turn knob has dual functions. 1) Turn the knob clockwise or counter clockwise to adjust the output level of the tuner (radio) source. 2) Push then turn the knob clockwise or counter clockwise to cycle up or down through the radio frequencies. Stop on a frequency and that station will be broadcast.

Preset Buttons 1-6 - The pre-set buttons provide access to the tuner pre-sets and work in conjunction with the AM/FM, Auto Scan, Memory and Clear buttons. Press pre-set buttons 1-6 to instantly recall stations once stations are stored in the pre-set memory. To instantly store a station, navigate to the desired station by pressing then turning the tune knob then press the memory button. Now press one of the pre-set buttons 1-6 then press the memory button to confirm and the station will be automatically stored in that location. NOTE: there are 4 pre-set levels and 48 pre-sets that can be stored in the internal memory. Press the AM/FM buttons to cycle from AM1, AM2, AM3, AM4, FM1, FM2, FM3, FM4 with 6 memory locations in each level.

AM/FM - The AM/FM buttons provide access to the AM band (press AM) and the FM band (press FM). Press these buttons repeatedly to access the 4 AM and 4 FM pre-set levels.

CLEAR - The CLEAR button clears stations from the memory. Press clear and the selected station will flash. Press clear again and the station will be erased from the pre-set memory. Press and hold the CLEAR button to instantly clear the station from the pre-set memory.

Memory - The memory button provides access to the internal pre-set memory locations. This feature is handy for changing memory locations. Navigate to a station. Press MEMORY and the preset memory location will flash. Press the desired pre-set location button 1-6. Press memory again and the station will be moved to the newly selected location. This is an easy way to store your favorite stations in locations that are easy to remember like memory location # 1.

Auto Scan - Press Auto Scan and the Tuner will scan all available AM then FM stations and load them into the internal memory in ascending order. This will overwrite all saved pre-sets.

ST/MONO - The CT-10 tuner is a stereo device. In some commercial sound applications it will be advantageous to change the output to mono. Switching the tuner to MONO will provide up to 5 mono line level outputs that can be used to feed multiple amplifiers.

SEEK + SEEK- - Press Seek + and the CT-10 will scan to the next valid station in ascending order. Press Seek - and the CT-10 will scan to the next valid station in descending order. Continue pressing Seek +/- until you find the station you are searching for.

Tuner Mute - The Tuner Mute mutes the tuner signal in the main speaker output and the line outputs. The tuner muting circuit is post MOH and pre-speaker/line output. If the Tuner is selected as the source for the MOH output the tuner will continue to broadcast on the MOH output when the mute is activated. Use the tuner mute when playing a constant music source or microphone from the PRO-RVC. This will stop the tuner from broadcasting in between spoken word phrases and pre-recorded songs but will maintain a constant music source for the MOH.

Rear Panel Operation and Connections.

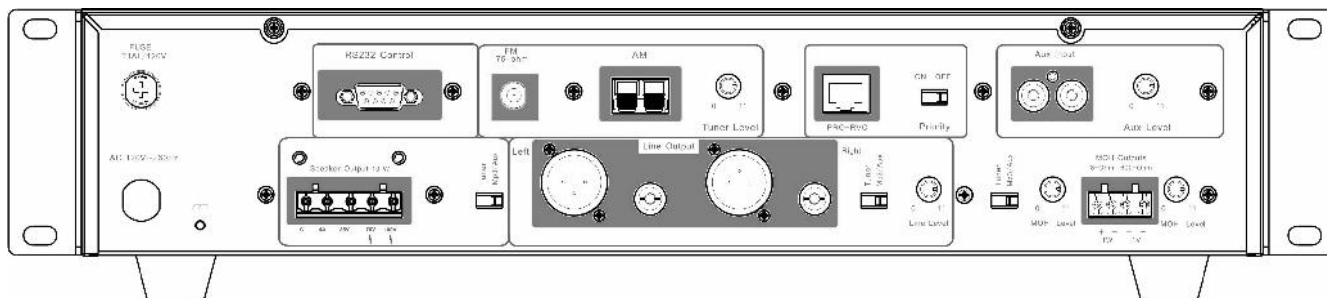

NOTE: Rear Panel color coding

GREEN = Input

RED = Output

RCA - These jacks accept line level signals from CD's, DVD's, Tuners etc. This is an unbalanced input that sums the signal to mono. The INPUT LEVEL knob does not affect the RCA input level.

MOH OUT - The MOH music on hold output offers two output levels. 1.) 600 ohm 1v balanced which is used to drive line level music on hold inputs. 2.) 8 ohm 1 watt which is used to drive phone systems that require more input gain. This output can also be used to power an 8 ohm loudspeaker. The MOH output can also be used as a Zone 2 output. Input 3 and the front panel Mp3 input signals are fed to the MOH output. All other inputs are fed to the main outputs. It is possible to have two completely different sources broadcasting simultaneously by using the MOH output to feed another amplifier or 8 ohm speaker and the main outputs to feed another group of speakers.

PRO-RVC - All Sound Acoustics amplifiers provide the unique PRO-RVC input. This is an RJ45 female jack that allows the connection of up to three PRO-RVC remote microphone/line mixers. This feature can provide up to 6 additional inputs (3 microphone & 3 line level) with individual volume control plus remote master volume control to any Sound Acoustics amplifier. The PRO-RVC connects with Cat5 cable providing one RJ45 input and one RJ45 output for daisy chaining up to three PRO-RVC's to each amplifier. Power for the PRO-RVC is provided by the amplifier and additional power supplies are not necessary. When using the PRO-RVC short the MUTE contacts if you want the PRO-RVC to maintain constant priority over other inputs connected to the amplifier. The PRO-RVC input provides a PRIORITY switch. Set the PRIORITY switch to ON for momentary override of other sources connected to the amplifier. Please read the PRO-RVC installation guide included with the PRO-RVC.

It is possible to use the PRO-RVC with other amplifier brands as a stand alone remote mic/line mixer by installing the optional RVC-ADAPT. Consult your authorized Sound Acoustics dealer for more information.

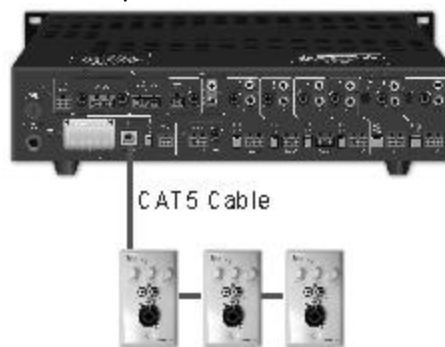

MODEL PRO-RVC

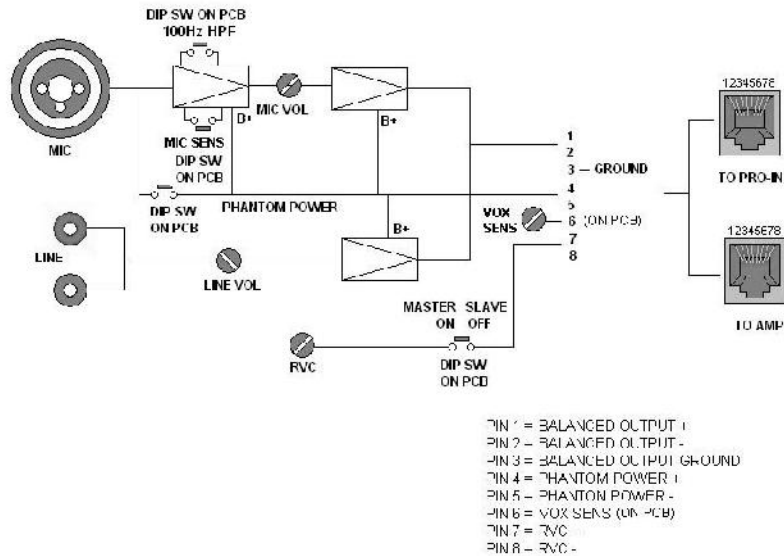

SPEAKER OUTPUTS - Sound Acoustics amplifiers provide 4 speaker level outputs. Do not use more than one output at a time. This could overload the amplifier. Remove the EURO style connector and select from the following chart.

C - Common or negative --

4 ohm - Connect to a direct coupled loudspeaker (no transformer) min impedance 4 ohms

25V - Connect to 25V transformer coupled loudspeakers.

70V - Connect to 70V transformer coupled loudspeakers

100V - Connect to 100V transformer coupled loudspeakers

RECOMMENED SPEAKER WIRE

Always use good quality stranded copper wire.

Speaker outputs

4 ohm 12-16 AWG stranded copper unshielded

25V 16-18 AWG stranded copper unshielded

70V 16-18 AWG stranded copper unshielded

100V 16-18 AWG stranded copper unshielded

CAUTION: Keep the speaker output guard on at all times. This will help prevent shock and fire hazards. Ensure the power cord is not connected to the AC outlet when making connections.

Line Level Outputs - The Line Level Output section offers stereo balanced professional XLR +4 dB outputs, unbalanced stereo RCA +4 dB outputs and a rotary level control to match output levels with other audio devices like amplifiers and mixers. All 4 output jacks are active all the time providing two constant stereo outputs or four MONO outputs with the front panel MONO feature engaged. This is a handy feature when distributing audio signals to multiple amplifiers.

AM ANTENNA INPUT - Connect the included AM antenna to receive AM radio stations by inserting the wires into the push terminals. The input terminals are not polarity sensitive. Note: It is impossible to receive AM signals without connecting an AM antenna.

FM 75-OHM INPUT - This is a coaxial 75 ohm terminal. Connect your cable-vision output to this jack or use the included external FM antenna for the best FM reception. NOTE: It is impossible to receive FM signals without an FM antenna.

POWER CORD - Connect the AC power cord to 120V AC outlets only. Do not connect the power cord until all audio connections are made. Serious damage may result if the amplifier is connected to line voltages other than 120V AC.

FUSE - TYPE T6, 3A/250V - Always use the correct fuse for replacement. Failure to use the correct fuse or shorting the fuse could result in fire and serious damage.

RS232 Control – This jack provides remote control of tuner functions using a personal computer. Connect the RS232 jack of your computer to this jack or use a USB to RS232 (DB9) converter to access these functions. The C-540T includes a software CD to load the tuner control installation wizard. After connecting the C-540T to your computer insert the installation CD into your computers CD/DVD drive and follow the installation wizard directions. Once the program is successfully installed you will have control of the following tuner functions: Select AM/FM and weather bands, select specific AM/FM frequencies, select AM/FM presets, Auto Scan, Seek+ Seek-, Memory functions and tuner volume.

Specifications	C-540T	CT-10	
Output Power RMS	40 watts	10 watts	
Frequency Response	40Hz- 20kHz	40Hz- 20kHz	
Total Harmonic Distortion	0.5% at rated power	0.5% at rated power	
Signal To Noise Ratio Mic	90dB	90dB	
Signal to Noise Ratio Line	90dB	90dB	
Signal to Noise Ratio Tel	75dB		
Signal to Noise Ratio Output			
Inputs Microphone	3 expandable to 6	3 via PRO-RVC	
Inputs Line Level	5 expandable to 8	2 expandable to 5	
Inputs Telephone	1		
Input PRO-RVC	1	1	
Chime with level adjust	1		
Speaker Level Outputs	4ohm,25,70,100V	4ohm,25,70,100V	
Line level Outputs	2	5	
MOH Output	8ohm 1W & 600 ohm 1V	8ohm 1W & 600 ohm 1V	
Remote Master Volume	Remote master volume contacts & PRO-RVC	Via PRO-RVC	
Tuner Specifications FM			
Tuning Frequency	87.5MHz to 108 MHz	87.5MHz to 108 MHz	
Usable Sensitivity	Less than 1 uv	Less than 1 uv	
Signal to noise ratio	Better than 75 dB	Better than 75 dB	
Total Harmonic Distortion	0.2 percent	0.2 percent	
Frequency Response	40Hz-18,000 Hz	40Hz-18,000 Hz	
Stereo Separation	65dB @ 1kHz	65dB @ 1kHz	
Tuner Specifications AM			
Tuning Frequency Range	520kHz to 1710kHz	520kHz to 1710kHz	
Usable Sensitivity	Less than 100 uv	Less than 100 uv	
Signal to Noise Ratio	Better than 55 dB	Better than 55 dB	
Rack Height	2U	2U	
Power Requirements AC	AC120V/60Hz	AC120V/60Hz	
Power Consumption AC	130W	50W	
Dimensions	8.5"W x 4"H x 11.25"D	17"W x 4" H x 11.25"D	
Shipping Weight			
Optional Accessories 1	Rack Kit SA-RK2.0	Rack Kit SA-RK2.0	
Optional Accessories 2	1-3 PRO-RVC	1-3 PRO-RVC	
Optional Accessories 3	SA-TEL1 600 ohm telephone isolation transformer		

Contact Information

Sound Acoustics HQ
1360 Frances Street
Vancouver BC Canada V5L 1Y9
E-mail: info@mysoundacoustics.com
Website: www.mysoundacoustics.com

Warranty

Sound Acoustics commercial amplifiers are warranted to be free from defects in workmanship and materials for a period of three (3) years without charge for parts or labour. The warranty applies only to the original owner. The owner's responsibilities are to provide proof of purchase and transportation to the dealer the unit was purchased from or transportation to the Sound Acoustics factory. This warranty does not apply to units which have been subject to misuse, abuse, neglect or improper installation, and does not apply to repairs or alterations by unauthorized personnel. This warranty specifically excludes responsibility for consequential damage.

Retention of your dated ORIGINAL BILL OF SALE is required to obtain service under the terms of the warranty.